



PRODUCT RELEASE

For Immediate Release

More Information Contact: Scott Becker, 916-631-8071

Summary:

Purpose: Announcement of the JK Control Arm Relocation Drop Bracket Kit
Products Referenced: JK Front Control Arm Relocation Drop Bracket Kit
Ease of Installation: Medium – Bolt on
Point of Contact: Scott Becker, Director of Marketing/Media, 916-631-8071
Website: www.Metalcloak.com
Location: 3290 Monier Circle, Suite 100, Rancho Cordova, CA 95742
Phone: 916-631-8071

MetalCloak's Control Arm Relocation Drop Bracket Kit

Lifted your JK Wrangler but still using the factory control arms and looking for a way to correct the front axle caster? Although factory control arms will not give you the added durability, adjustment or articulation of the MetalCloak Duroflex Control Arms, they are a great way to reduce the cost of lifting your JK, but they will need a little help. Restore the factory handling for less than half the price of lower control arms without using cam-bolts. MetalCloak's Control Arm Relocation Drop Bracket Kit reuses the factory control arms and corrects the front axle caster for 2.5", 3.5", and 4.5" lift heights. The Drop Brackets are made of 7 gauge steel welded into one piece to be the strongest and simplest to install. Finished in MetalCloak's signature black texture powdercoat. Get the most out of your factory suspension parts with MetalCloak. MetalCloak, It's your Jeep Only Better. Information: MetalCloak, 916-631-8071, www.Metalcloak.com

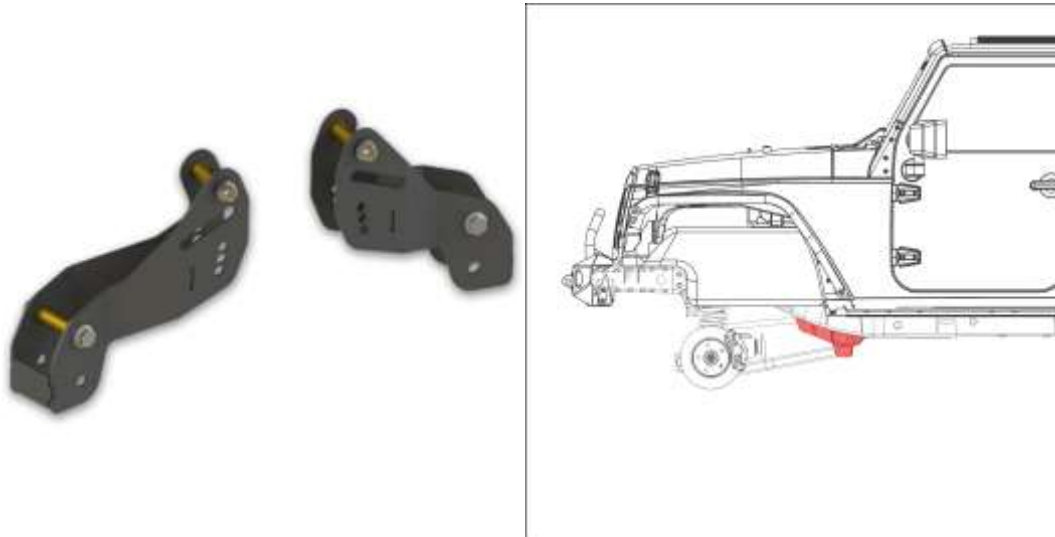

[Click Here for More Information](#)