



METALCLOAK

INSTALLATION INSTRUCTIONS

PRODUCT: TJ/LJ/YJ FRONT FENDER FLARE

REV: D | 7-14-10 | II-2240

READ INSTRUCTIONS IN FULL BEFORE INSTALLATION.

QUESTIONS? CALL 916-631-8071 M-F 8:00 AM – 5:00 PM PST

The MetalCloak experience includes the ease of installation of our products. We design for most contingencies, but installation may be different based on different Jeep condition, configuration and/or year.

We are continually trying to improve our products and instructions – please help us by providing feedback and pictures if you find any part of the instructions that do not match your particular Jeep or are not easily understandable.

If you have any difficulties at all, please give us a call. Thank you and enjoy your MetalCloak Products!

IMPORTANT NOTE: We use Stainless Steel Hardware where possible. Therefore, a tube of Silver Anti-seize is provided and should be used on all bolts—only a small amount is needed.

WARRANTY INFORMATION: This article is sold without warranty expressed or implied. No warranty or representation is made as to this products ability to protect the user from injury or death. The user assumes that risk. The effectiveness, warranty and longevity of this equipment are directly related to the manner in which it is INSTALLED, USED and/or MAINTAINED. THE USER ASSUMES ALL RISK. By purchasing this product and opening the packaging, purchasers expressly acknowledge, understand and agree that they take, select and purchase these MetalCloak products from Armored Works, LLC, its affiliates and distributors and agents as is and with all faults. The entire risk as to the quality and performance of these MetalCloak products is with the purchaser. Working on your vehicle can be a dangerous activity. If you are unsure of what you are doing, please leave mechanical or safety critical work to a skilled mechanic. We take no responsibility for the incorrect use and/or installation of MetalCloak products.

Phase 1: Tools & Notes on Installation

Tools Required: This list is the recommended tools for ease of installation. Other versions of the same tool can be used. For example, Allen Wrenches instead of Allen Drive Sockets.



Socket & Ratchet Wrench



5/32" Allen Drive Socket or Wrench

Installation Notes: Terms may be used in the body of the instructions that you may not be familiar with, if you have any questions feel free to call us at 916-631-8071 M-F 8:00 AM – 5:00 PM PST, or email techhelp@metalcloak.com

HOW TO USE THIS GUIDE: The installation guide contains ALL steps for installing your fender flares. Please read and follow the instructions in order of each page top to bottom.

Images: Pictures are provided and parts are labeled throughout the instructions. Each text box contains guidance based on the pictures next to it. The text will refer to alphabetical labels (A, B, etc) found in the images.

QUESTIONS: Any questions or comments about the instructions? Call us at 916-631-8071 M-F 8:00 AM – 5:00 PM PST.

Phase 1: Flare Installation

Step 1: Align Rear Ball

Rest Flare(A) on front tire in preparation of mounting.



Align the rear ball(B) of the fender flare with the mounting boss(C) on the Front Fender.

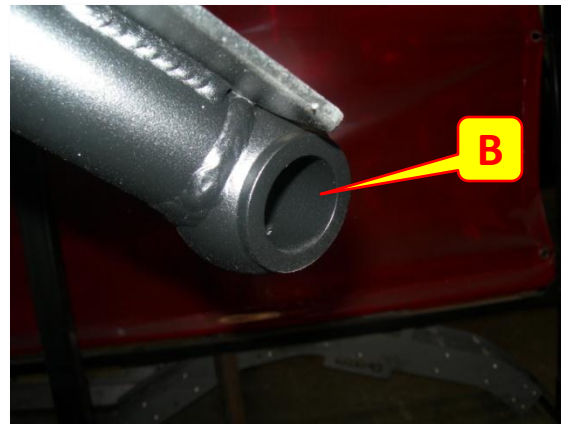

Using the supplied 3/8"-16 flathead socket screw, bolt on flare ball. Tighten screw until almost snug.



ATTENTION: Use provided silver anti-seize on the flathead socket screw



Phase 1: Flare Installation

Step 2: Align Front Ball

To align to flare with the fender, pivot the flare into place using the snug rear bolt. Align the middle of the flare near the middle of the fender.



Once the flare is pivoted to the proper position, a small gap will remain between the mounting ball and the mounting boss. This is an expected part of the MetalCloak Flex Strength System



Press slightly on the ball to snap the flare into the proper place



Insert self centering bolt through front mounting ball and tighten.



Clean up and Enjoy your New MetalCloak Trail Engineered Body Armor!



Full tighten both bolts. When both bolts are fully tightened, our Trail Engineered Solid Mounting System will keep the flares from moving at all

Why the small gap? The MetalCloak Flex Strength System ensures a long-lasting tight fit for your flares. When the front bolt is fully tightened, the tension on the flare will prevent rattling and provide your system with increased integrity.

REMOVING FRONT FLARES: MetalCloak Front Flares can be removed at any time to provide you with additional clearance while offroading. To remove, simply follow all installation steps in reverse order

	1	2	3	4	5	6	7	8
ITEM	PART NUMBER/DESCRIPTION			QTY				
	1	WM-0010 WELDMENT, 4 FRONT FLARE TJ-LJ			1			
	2	WM-0010-P WELDMENT, 4 FRONT FLARE TJ-LJ			1			
E	3	FA-0045 SFHCSCREW, .375-16 x 1.75L 18-8 SS			4			

NOTES:

1) USE ANTI-SEIZE ON ALL STAINLESS STEEL FASTENERS

D

C

B

A

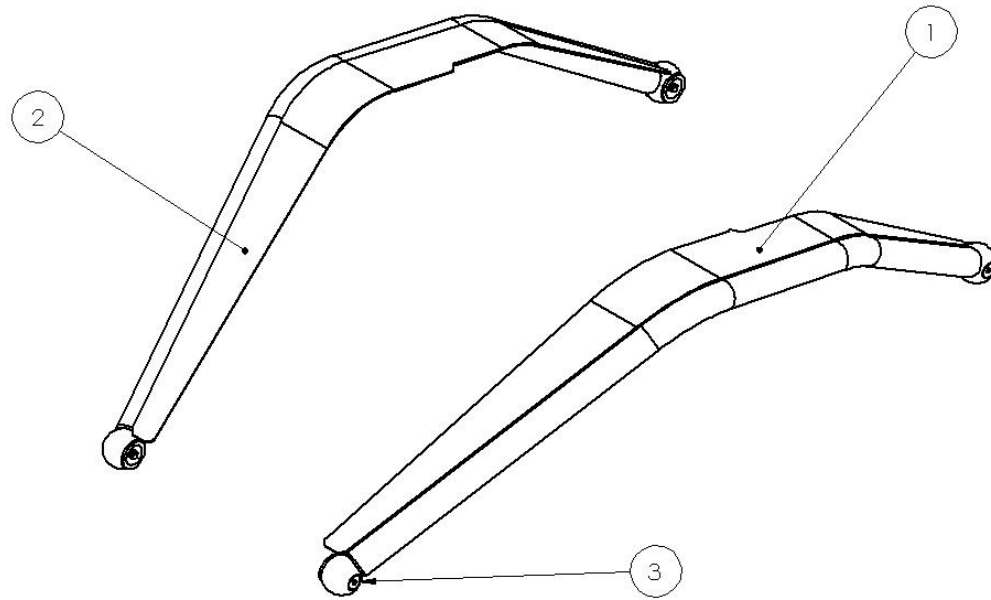

THE INFORMATION CONTAINED IN THIS DOCUMENT IS THE SOLE AND EXCLUSIVE PROPERTY OF ARMORED WORKS, LLC. ANY REPRODUCTION OF THIS DOCUMENT WITHOUT THE WRITTEN PERMISSION OF ARMORED WORKS, LLC. IS STRICTLY PROHIBITED. METALCLOAK IS A DIVISION OF ARMORED WORKS, LLC. FOR MORE PRODUCT INFORMATION GO TO WWW.METALCLOAK.COM COPYRIGHT 2009 ALL RIGHTS RESERVED



REVISION	[B][DHP][04/08/10]	PART NUMBER DESCRIPTION
----------	--------------------	-------------------------

2240 FRONT FLARE, 4 INCH TJ-LJ-YJ