



## PRODUCT: JL Rear Inner Fender Wells

REV: A | 04-17-2019 | II-6291

**READ INSTRUCTIONS IN FULL BEFORE INSTALLATION.  
QUESTIONS? CALL 916-631-8071 M-F 7:00 AM – 5:00 PM PST**

The MetalCloak experience includes the ease of installation of our products. We design for most contingencies, but installation may be different based on different Jeep condition, configuration and/or year.

We are continually trying to improve our products and instructions – please help us by providing feedback and pictures if you find any part of the instructions that do not match your particular Jeep or are not easily understandable.

If you have any difficulties at all, please give us a call. Thank you and enjoy your MetalCloak Products!

**IMPORTANT NOTE: We use Stainless Steel Hardware where possible. Therefore, a tube of Silver Anti-seize is provided and should be used on all bolts—only a small amount is needed.**

**WARRANTY INFORMATION:** This article is sold without warranty expressed or implied. No warranty or representation is made as to this products ability to protect the user from injury or death. The user assumes that risk. The effectiveness, warranty and longevity of this equipment are directly related to the manner in which it is INSTALLED, USED and/or MAINTAINED. THE USER ASSUMES ALL RISK. By purchasing this product and opening the packaging, purchasers expressly acknowledge, understand and agree that they take, select and purchase these MetalCloak products from Armored Works, LLC, its affiliates and distributors and agents as is and with all faults. The entire risk as to the quality and performance of these MetalCloak products is with the purchaser. Working on your vehicle can be a dangerous activity. If you are unsure of what you are doing, please leave mechanical or safety critical work to a skilled mechanic. We take no responsibility for the incorrect use and/or installation of MetalCloak products.

## Section 1: Tools & Notes on Installation



**Tools Required:** This list is the recommended tools for ease of installation. Other versions of the same tool can be used. For example, Allen Wrenches instead of Allen Drive Sockets.



Socket & Ratchet Wrench

7/32" Allen Drive Socket or Wrench  
5/32 Allen Drive Socket or Wrench



Plastic Rivet Removal Tool  
or Flat-head Screwdriver

9/16" Box Wrench  
7/16" Box Wrench



**HOW TO USE THIS GUIDE:** The installation guide contains ALL steps for installation. Please read and follow the instructions in order of each page from top to bottom, and left to right.

**Jeep Model:** Instructions may apply to multiple Jeep models, but are labeled separately where appropriate (i.e. TJ vs. LJ).

**Options:** Because of the number of component options we offer, these instructions may contain steps that will not match your particular configuration. You can skip these steps.

**Images:** Pictures are provided and parts are labeled throughout the instructions. Each text box contains guidance based on the pictures next to it. The text will refer to alphabetical labels (A, B, etc) found in the images.

**Installation Notes:** Terms may be used in the body of the instructions that you may not be familiar with, if you have any questions feel free to contact us at the number below, or email [techhelp@metalcloak.com](mailto:techhelp@metalcloak.com)

**QUESTIONS:** Any questions or comments about the instructions? Call us at 916-631-8071 M-F 7:00 AM – 5:00 PM PST.

## Section 2: Product Components

DC-0001 REV A

SHEET 1 OF 1

ITEM	PART NUMBER/DESCRIPTION	QTY.
1	CP-6022 FRONT STRAP, INNER FENDER, JL REAR	1
2	CP-6022-P FRONT STRAP, INNER FENDER, JL REAR	1
3	FS-04003 WASHER, 0.28ID X 0.63OD X 0.05TH SS 18-8	18
4	FS-04005 NYLOCK NUT, 0.25-20 X 0.31H STL GF ZINC	9
5	FS-04006 SBHCS, 0.25-20 X 0.75L SS 18-8 PLAIN	9
6	WM-6015 WELDMENT, INNER FENDER, JL REAR DRIVE	1
7	WM-6016 WELDMENT, INNER FENDER, JL REAR PASS	1

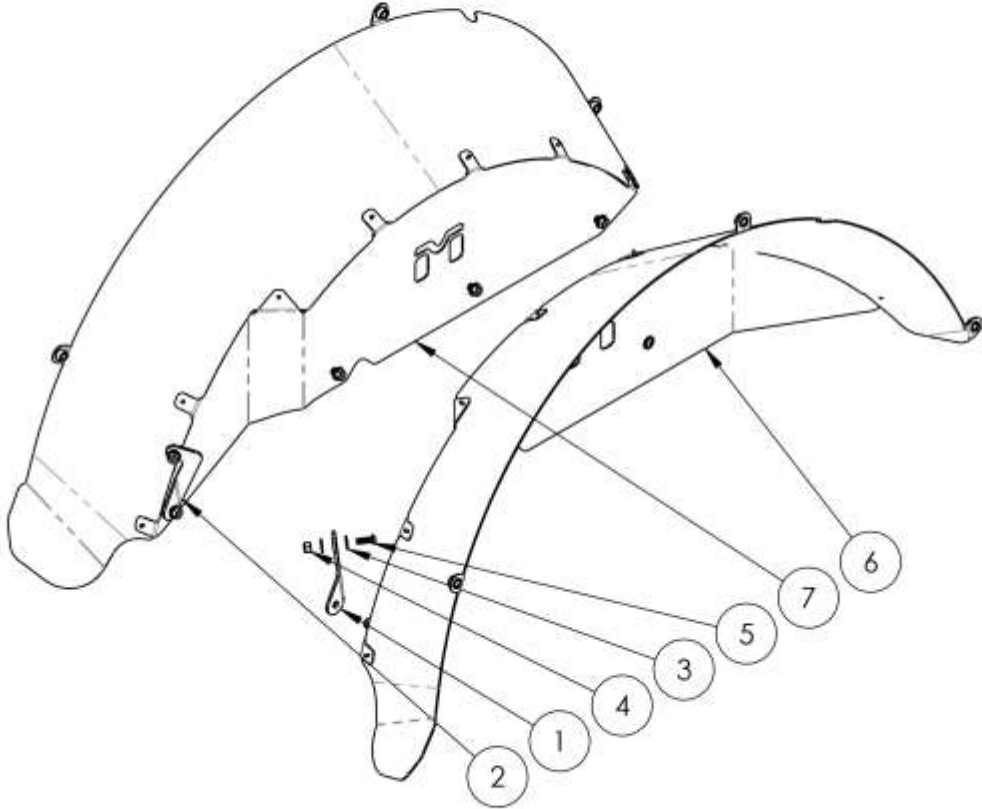
The drawing shows an exploded view of the inner fender well assembly. Callout 1 points to the front strap, 2 to the front strap part, 3 to the washers, 4 to the nylock nuts, 5 to the screw bolts, 6 to the drive weldment, and 7 to the pass weldment. The assembly is shown in a perspective view, with dashed lines indicating the relative positions of the components.

THE INFORMATION CONTAINED ON THIS DRAWING IS THE EXCLUSIVE PROPERTY OF ARMORED WORKS, LLC. UNAUTHORIZED REPRODUCTION IS PROHIBITED.  
**DO NOT SCALE DRAWING**  
**Metal Cloak**  
 A DIVISION OF ARMORED WORKS, LLC

**PART NUMBER/DESCRIPTION**  
 6291 INNER FENDER WELL, JL REAR

## Section 3: Installation Instructions

### Step 1: Remove Rear Stock Inner Fender Liner

- A. Remove the Rear plastic inner fender liners by removing the plastic rivets.
- B. Remove the three marked bolts on your MetalCloak fender using a 7/32 allen wrench and a 9/16 wrench. **SAVE ALL HARDWARE.**

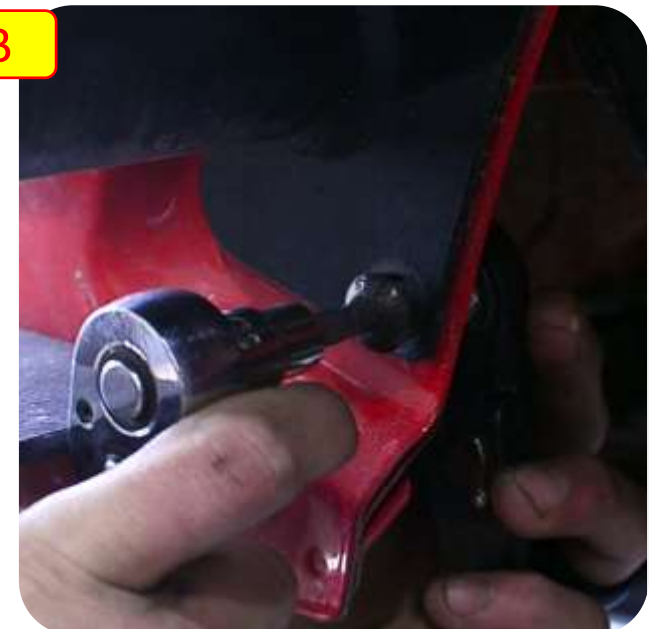



## Section 3: Installation Instructions

### Step 2: Install Rear Inner Fender Well

- C. Using a 5/32 allen wrench and a 7/16 wrench install the provided bracket making sure the bent tab is pointing inward.
- D. Loosely Install the top fender bolt you removed in step B to hold the fender well into place.
- E. Install the provided hardware into the lower fender well holes. Make sure bolt 4 is installed into the bracket (step C) as well.

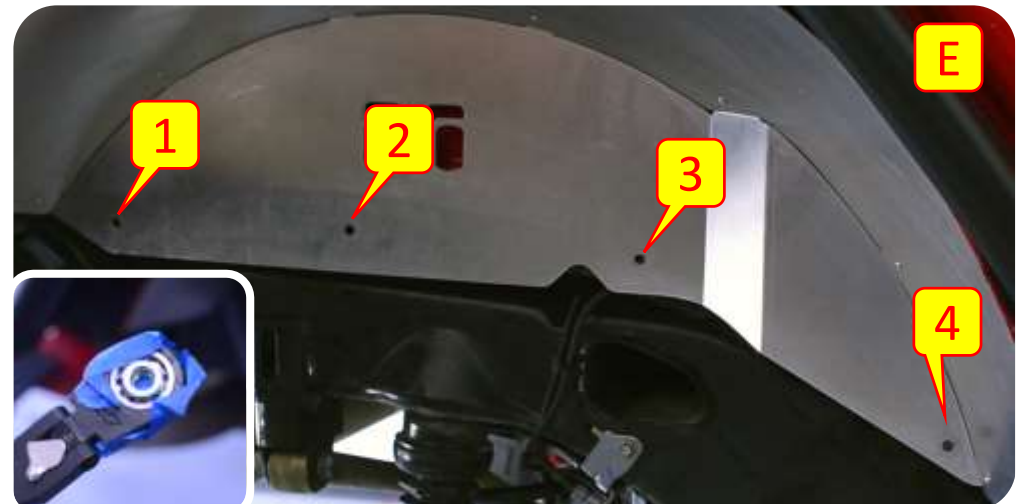
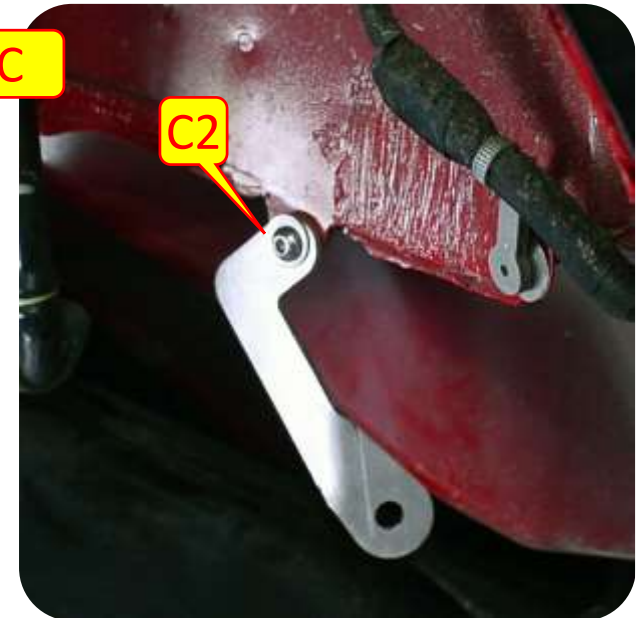
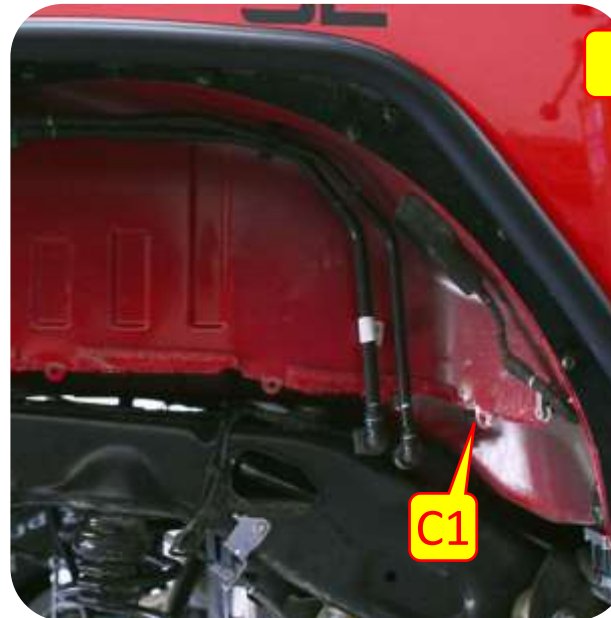

**Important Note:** MetalCloak Recommends applying tape to a 7/16 wrench to hold the nut in place during installation.

## Section 3: Installation Instructions



### Step 2: Install Rear Inner Fender Well

- F. Install the remaining two fender bolts.
- G. Tighten all Hardware.

**Fender Bolts:** *7/32 allen wrench*  
*9/16 wrench*

**Fender Well Bolts:** *5/32 allen wrench*  
*7/16 wrench*

