



PRODUCT: JL Overland Rear Fender

REV: A | 11-21-2018 | II-6400

**READ INSTRUCTIONS IN FULL BEFORE INSTALLATION.
QUESTIONS? CALL 916-631-8071 M-F 7:00 AM – 5:00 PM PST**

The MetalCloak experience includes the ease of installation of our products. We design for most contingencies, but installation may be different based on different Jeep condition, configuration and/or year.

We are continually trying to improve our products and instructions – please help us by providing feedback and pictures if you find any part of the instructions that do not match your particular Jeep or are not easily understandable.

If you have any difficulties at all, please give us a call. Thank you and enjoy your MetalCloak Products!

IMPORTANT NOTE: We use Stainless Steel Hardware where possible. Therefore, a tube of Silver Anti-seize is provided and should be used on all bolts—only a small amount is needed.

WARRANTY INFORMATION: This article is sold without warranty expressed or implied. No warranty or representation is made as to this products ability to protect the user from injury or death. The user assumes that risk. The effectiveness, warranty and longevity of this equipment are directly related to the manner in which it is INSTALLED, USED and/or MAINTAINED. THE USER ASSUMES ALL RISK. By purchasing this product and opening the packaging, purchasers expressly acknowledge, understand and agree that they take, select and purchase these MetalCloak products from Armored Works, LLC, its affiliates and distributors and agents as is and with all faults. The entire risk as to the quality and performance of these MetalCloak products is with the purchaser. Working on your vehicle can be a dangerous activity. If you are unsure of what you are doing, please leave mechanical or safety critical work to a skilled mechanic. We take no responsibility for the incorrect use and/or installation of MetalCloak products.

Section 1: Tools & Notes on Installation

Tools Required: This list is the recommended tools for ease of installation. Other versions of the same tool can be used. For example, Allen Wrenches instead of Allen Drive Sockets.



Socket & Ratchet Wrench

7/32" Allen Drive Socket or Wrench



3/8" Drill Bit
17/32" Drill Bit

Drill



Center Punch

9/16" Box Wrench



Plastic Rivet Removal Tool
or Flat-head Screwdriver

HOW TO USE THIS GUIDE: The installation guide contains ALL steps for installation. Please read and follow the instructions in order of each page from top to bottom, and left to right.

Jeep Model: Instructions may apply to multiple Jeep models, but are labeled separately where appropriate (i.e. TJ vs. LJ).

Options: Because of the number of component options we offer, these instructions may contain steps that will not match your particular configuration. You can skip these steps.

Images: Pictures are provided and parts are labeled throughout the instructions. Each text box contains guidance based on the pictures next to it. The text will refer to alphabetical labels (A, B, etc.) found in the images.

Installation Notes: Terms may be used in the body of the instructions that you may not be familiar with, if you have any questions feel free to contact us at the number below, or email techhelp@metalcloak.com

QUESTIONS: Any questions or comments about the instructions? Call us at 916-631-8071 M-F 7:00 AM – 5:00 PM PST.

Section 2: Product Components

DC-0001 REV A

SHEET 1 OF 1

ITEM	PART NUMBER/DESCRIPTION	QTY.	BIN
1	8999 INSTALLATION TOOL, 0.38-16 RIVET NUT	1	
2	WM-6060 WELDMENT, OVERLAND FLARE, JL REAR	1	
3	WM-6060-P WELDMENT, OVERLAND FLARE, JL REAR	1	
HK-6400			
4	FS-06004 WASHER, 0.41ID X 0.81OD X 0.05TH SS 18-8	14	B5
5	FS-06010-BZ SBHCS, 0.38-16 X 1.0L STL G8 BLACK ZINC	26	A37
6	FS-06030 NYLOCK NUT, 0.38-16 X 0.45H STL GF ZINC	14	B14
7	FS-06033 RIVET NUT, 0.38-16 X 0.15GRIP STL G5 GOLD ZINC	14	C22
8	FS-06073 SFHCS, 0.38-16 X 0.75L SS 18-8 PLAIN	2	B23
9	FS-06196 SFHCS, 0.38-16 X 4.5L SS 18-8 PLAIN	2	

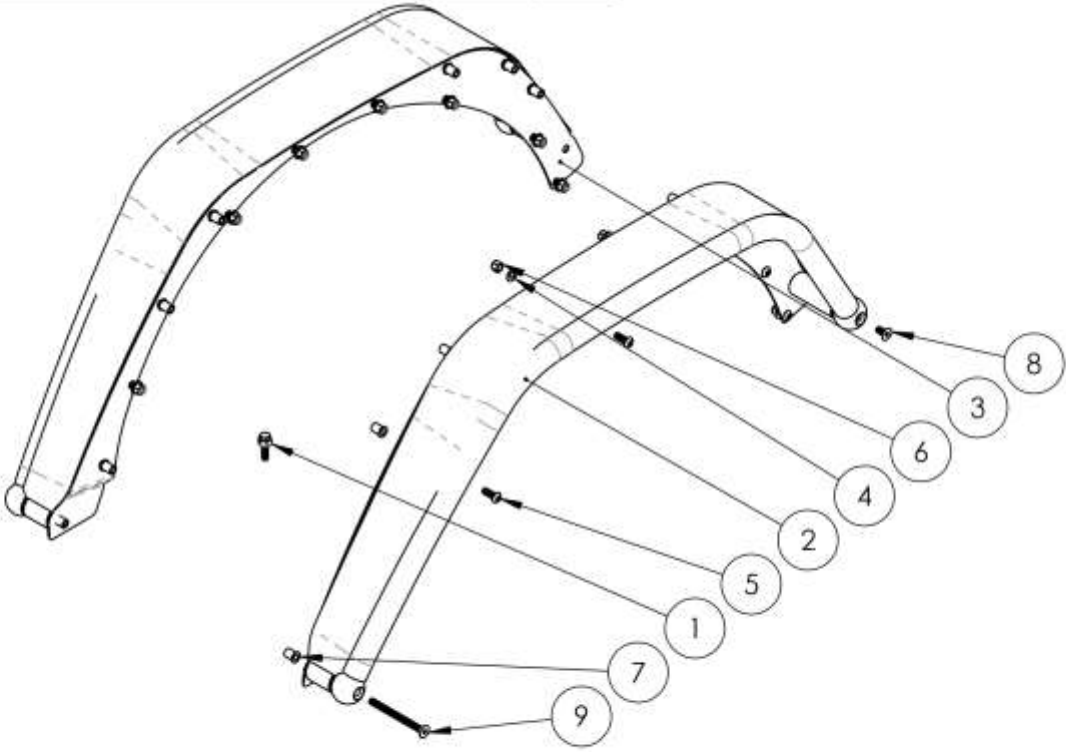

THE INFORMATION CONTAINED ON THIS DRAWING IS THE EXCLUSIVE PROPERTY OF ARMORED WORKS, LLC. UNAUTHORIZED REPRODUCTION IS PROHIBITED.
DO NOT SCALE DRAWING

Metal Cloak
 A DIVISION OF ARMORED WORKS, LLC

PART NUMBER/DESCRIPTION
 6400 OVERLAND FLARE, JL REAR

Section 3: Installation Instructions



Step 1: Remove Front Stock Fender and Inner Fender Well

- A. Remove the plastic rivets. You may choose to cut these off if you do not have a Plastic Rivet Removal Tool readily available.
- B. Pull the flares up and away from the jeep, working from one end of the flare to the other.
- C. Remove the remaining plastic clips with a pair of needs nose pliers



Note: Do not be concerned if you break some clips in the process, you will not need them.



Section 3: Installation Instructions



Step 2: Rear Overland Fender Installation

- D. Drill the stock holes marked in the diagram to $17/32$ " in preparation for the rivet nuts.
- E. Install the Rivet Nuts in the holes that have been opened and created making sure that when installing the Rivet Nuts you set them exactly perpendicular to the sheet metal.
- F. Align the fender to the tub and install the provided hardware into the rivet nut holes hand tight.



Section 3: Installation Instructions

Step 2: Rear Overland Fender Installation

- G. Mark the remaining holes and center punch for drilling.
- H. Remove the overland fender and drill out the marked holes to 3/8". MetalCloak recommends painting any exposed metal after drilling.
- I. Re align the fender and install the hardware hand tight.
- J. Install the long counter sunk bolt into the front ball and the shorter in the rear ball.
- K. Tighten all hardware
Rivet nut hardware: 7/32" Allen wrench
Countersunk hardware: 7/32" Allen wrench
Remaining Bolts: 9/16" wrench / 7/32" Allen wrench

